



<http://dx.doi.org/10.35596/1729-7648-2023-21-5-59-67>

Original paper

UDC 621.396.6

PARAMETER OPTIMIZATION OF NOISE-REDUCTION FILTERS OF HI-PERFORMANCE POWER SUPPLIES

ANASTASIA A. SHMELKOVA¹, VLADIMIR V. ANDREEV¹, VLADIMIR E. DRACH²

¹*Kaluga Branch of Moscow State Technical University named after N. E. Bauman (Kaluga, Russian Federation)*

²*Sochi State University (Sochi, Russian Federation)*

Submitted 18.04.2023

© Belarusian State University of Informatics and Radioelectronics, 2023

Белорусский государственный университет информатики и радиоэлектроники, 2023

Abstract. For a noise-reduction filter, the parameters of the manufactured device often do not fit the expected parameters during development, what is caused by the spread of the parameters of the electronic components or their parasitic parameters, as well as due to the presence of its own capacitance and inductance of the frequency response assembly. In this article, the influence of parasitic parameters of components and fasteners on the filter frequency response is considered. Utilizing the electronic simulator software, the filter parameters were modeled in the frequency range from 10 kHz to 1 GHz. Based on the simulation results, recommendations were given for optimizing the filter mounting elements and changing the inductance of low-frequency chokes.

Keywords: noise-reduction filter, parasitic parameters, frequency response, modelling.

For citation. Shmelkova A. A., Andreev V. V., Drach V. E. (2023) Parameter Optimization of Noise-Reduction Filters of Hi-Performance Power Supplies. *Doklady BGUIR*. 21 (5), 59–67. <http://dx.doi.org/10.35596/1729-7648-2023-21-5-59-67>.

ОПТИМИЗАЦИЯ ПАРАМЕТРОВ ШУМОПОДАВЛЕНИЯ ФИЛЬТРОВ ВЫСОКОПРОИЗВОДИТЕЛЬНЫХ ИСТОЧНИКОВ ПИТАНИЯ

А. А. ШМЕЛЬКОВА¹, В. В. АНДРЕЕВ¹, В. Е. ДРАЧ²

¹*Калужский филиал Московского государственного технического университета имени Н. Э. Баумана
(г. Калуга, Российская Федерация)*

²*Сочинский государственный университет (г. Сочи, Российская Федерация)*

Поступила в редакцию 18.04.2023

Аннотация. Параметры готового электронного изделия могут не соответствовать расчетным, что обусловлено, например, неучтенными паразитными связями. По этой причине при конструировании помехоподавляющих фильтров эффективность фильтрации может быть занижена по сравнению с ожидаемой. Проведено моделирование изменения амплитудно-частотной характеристики фильтра, обусловленное влиянием паразитных параметров компонентов и элементов механического крепежа, в диапазоне частот от 10 кГц до 1 ГГц. Предложены рекомендации по модификации элементов механического крепления и оптимизации параметров дросселей низкой частоты.

Ключевые слова: помехоподавляющий фильтр, паразитные параметры, амплитудно-частотная характеристика, моделирование.

Для цитирования. Шмелькова, А. А. Оптимизация параметров шумоподавления фильтров высокопроизводительных источников питания / А. А. Шмелькова, В. В. Андреев, В. Е. Драч // Доклады БГУИР. 2023. Т. 21, № 5. С. 59–67. <http://dx.doi.org/10.35596/1729-7648-2023-21-5-59-67>.

Introduction

A noise-reduction filter is required for pulsed power supplies to protect the supply lines of the primary and secondary circuits from high-frequency interference generated by a pulsed transformer. This filter must protect against both in-phase and antiphase interference at the same time. In-phase interference is formed between the supply line and the common wire of the circuit, and antiphase interference is formed between two wires of the circuit. The parameters of the developed and manufactured device often do not meet the expected ones, what is caused by the spread of the parameters of the electric components or their parasitic parameters, as well as due to the presence of its own capacitance and the inductance of the PCB assembly.

The relevance of the problem is directly related to the real tasks that engineering and technical workers of commercial enterprises have to solve. The authors were interested in the task to find out the reasons for the underestimated attenuation coefficient of the broadband noise-reduction filter, which for many years has been successfully tested according to the methodology approved in the technical specifications for the product. However, studies of filters using modern hybrid techniques have revealed a discrepancy between parameters (frequency response and attenuation coefficient, for example) of real manufactured device and parameters declared in technical specifications. Determining the cause of this discrepancy is not an easy task, which includes an in-depth analysis of the product design and the use of indirect evaluation methods.

Simulation software and technique

In order to find out the reasons for the discrepancy between real and required filter parameters, we combined laboratory tests, real component measurements and computer modeling for a qualitative analysis of the interaction of components. The open source QUCS software [1] was chosen for modeling purposes due to verbatim results [2], convenient filter modeling [3], and possibility to measure the S-parameters of a quadripole, which is useful for designing high-frequency circuits. The only disadvantage is the impossibility to simulate the electrical circuits in real-time mode.

The scheme of the initial filter is shown in Fig. 1, it is a U-shaped filter that protects against symmetrical and asymmetric interference. Elements of E are ceramic noise-reduction filters of B14 type, designed to filter high-frequency interference. The attenuation coefficient within the operating range must be at least 60 dB for specific frequencies of 0.05, 0.1, 10, 30, 100 and 400 MHz.

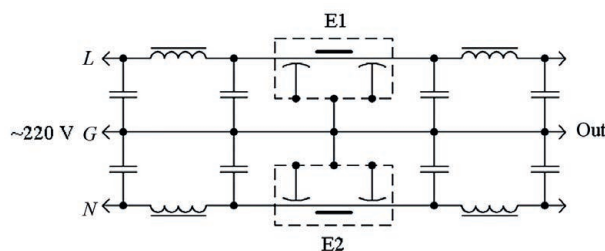

Fig. 1. Electrical diagram of the noise-suppressing filter

First of all, we will model a filter with ideal parameters in order to have a reference frequency response for a reference. Since two filter channels are identical, it is enough to model only one channel to evaluate the parameters. The parameters of the capacitors are known, and the inductance parameters are determined experimentally, their measurement will be explained below.

The filter model is shown in Fig. 2, 3 – its frequency response. Neither the parasitic parameters of the components nor the influence of the elements on each other are considered here. It should be noted (and this will be true for almost the entire article) that the modeled frequency response makes it clear to represent the behavior of a quadripole at different frequencies only, but does not quantify its attenuation: the data is incorrect.

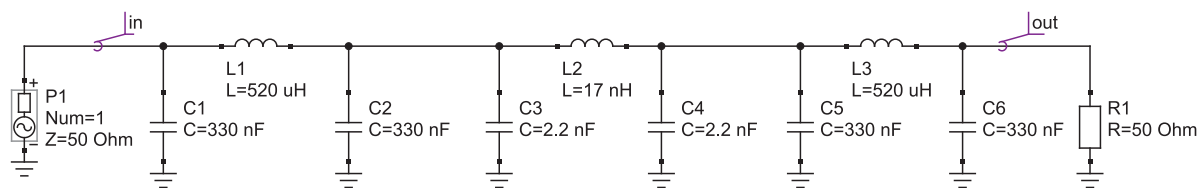

Fig. 2. Ideal filter model

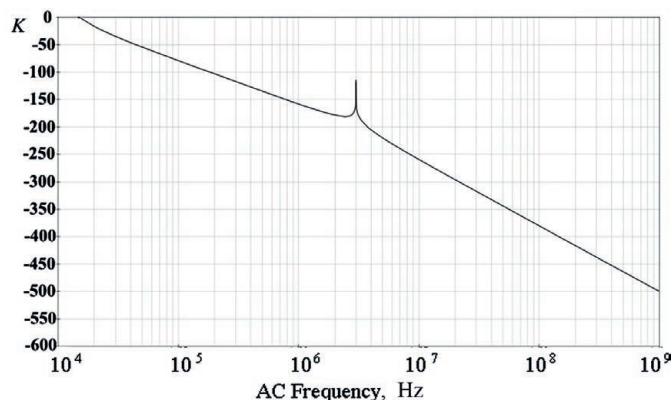

Fig. 3. Frequency response of the ideal filter

Binding to the obtained values of the attenuation coefficient is possible only at relatively low frequencies, where the nonlinear parameters of the components are not affected yet and they can be considered relatively ideal. Practically, these are frequencies up to 50–100 kHz.

The filter pole lies between 10 and 20 kHz, the spike at a frequency of 3 MHz is due to the resonance of the middle element. For further analysis, it is necessary to supplement the model with parasitic parameters that exist in any real component.

System model

A. Real components parameters

Depending on the type of capacitor, its characteristics and frequency range, a real capacitor can be represented by various equivalent circuits. In the most general form, the circuit of a real capacitor is shown in Fig. 4 (on the top).

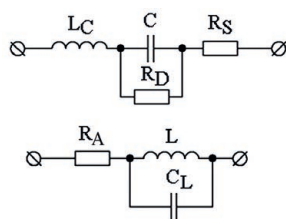

Fig. 4. Replacement circuits of the capacitor (top) and the inductor (bottom): L_C is the inductance of the terminals and plates of the capacitor; R_D is the active resistance of the dielectric; R_S is the equivalent series resistance; R_A is the active resistance of the terminals and plates of the capacitor

The measurement of intrinsic inductance presents certain difficulties, since it strongly depends on the length of the terminals, their relative position and orientation relative to the device and its terminal devices. It is enough to slightly change the location of the wires or the orientation of the capacitor terminals during measurement, as it is possible to obtain a new inductance value that differs several times from the previously measured one [4].

The value of the dielectric resistance R_D is rarely used for practical tasks, since it is a sufficiently large value, which is inconvenient to operate. The measure of energy loss in a dielectric is much more widely used, to do this, a special variable was introduced: the tangent of the dielectric loss angle ($\tan \delta$).

The measure of energy loss in a dielectric is much more widely used – the tangent of the dielectric loss angle $\tan\delta$. Then we can write an expression for the active power dissipated by the dielectric

$$P_A = U^2 X_C \tan \delta, \quad (1)$$

where U is the voltage applied to the capacitor; X_C is the reactance of the capacitor at a given frequency. The dielectric loss tangent itself for a given substitution circuit is defined as

$$\tan \delta = (R_D \omega C)^{-1}, \quad (2)$$

where R_D is the dielectric resistance; ω is the cyclic frequency; C is a capacitance of the capacitor [4].

B. Measurement of parasitic parameters of components

Not all parasitic parameters can be measured directly. These parameters include the equivalent series resistance of the capacitor R_S and the capacitance of the coil C_L . The equivalent series resistance of the capacitor is usually fractions of ohms for capacitors with high capacitance and low voltage, and can reach two or more ohms for elements with low capacitance and high voltage.

For the combined capacitors K75-10 used in the noise-reduction filter under study, the equivalent series resistance will consist of the active resistance of the plate R_A and the active resistance of the terminals R_T

$$R_S = R_A + R_T. \quad (3)$$

The equivalent series resistance is measured by applying a square wave with a frequency of about 50 kHz and the amplitude equal to several dozens of volts to the tested capacitor, which is connected in series with a low-resistance resistor. The AC voltage that occurs in this resistor is measured and displayed on the indicator.

Measuring the parasitic capacitance of inductors is a more non-trivial task. Depending on the frequency at which the coil operates, different measurement methods have to be used. One of the ways to determine the parasitic capacitance is to determine the Q -factor (Q) of the oscillatory circuit formed by the inductance and its parasitic capacitance. As is known, the Q -factor of the circuit is a measure of the ideality of the oscillatory circuit, showing how many times the impedance of the oscillatory circuit changes at the resonant frequency compared to the low-frequency value. For an ideal parallel oscillatory circuit at a resonant frequency, the impedance tends to infinity, for a real one, it will increase by Q times. The Q -factor for a parallel resonant circuit is generally defined as

$$Q = R\sqrt{C/L}. \quad (4)$$

It's necessary to emphasize that calculating of the Q -factor of a particular contour is a task depending on various parameters [5–10]. In practice, it's possible to measure the Q -factor using a special device, so-called Q -factor meter. For this study, the E4-11 model was used. It operates in the frequency range of 30–300 MHz and measures Q -values from 10 to 1000. Its convenience is the direct reading of the values on the scale of the measuring head. Furthermore, this device makes it possible to measure the inductance of the coils and (what is important) the parasitic capacitance of inductors. Note that for a minimum measurement error, the coil terminals must be connected directly to the meter terminals, without any intermediate wires.

The authors made a sample from a batch of B14 filters in the amount of 36 items and measured their parameters. The average values were as follows: parasitic capacitance – 1.67 pF, filter inductance – 17 nH. The obtained values will be used in the future for modeling. It was not possible to measure the parasitic capacitance of other filter coils using a Q -factor meter, since the resonant frequency of the chokes is much lower than the operating frequency of the E4-11 meter. The method of direct measurement of the resonant frequency works better here. Since the inductor with its parasitic capacitance represents a parallel oscillatory circuit, then its parasitic capacitance is calculated by determining the resonant frequency of the coil and measuring its inductance.

The circuit of the measuring unit is shown in Fig. 5. The oscillating circuit is powered by a low-frequency oscillator with a frequency adjustable in the range of 10 Hz to 10 MHz. A precise oscilloscope was used as a resonance indicator. The resonance indicator is connected to a current sensor – a resistor plugged in series with the circuit.

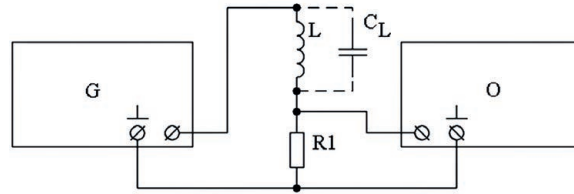

Fig. 5. Experimental setup for determining the parasitic capacitance of inductors:
G – generator; O – oscilloscope

The resonance is determined visually by the minimum amplitude of the oscillation on the oscilloscope screen. Since the accuracy of visual control is low, there is no frequency meter in the installation to accurately determine the resonance frequency; the resonant frequency is read directly from the sight of the frequency adjustment knob. The capacity was measured for 20 devices, the average value was equal to 82.6 pF.

C. Filter model with parasitic parameters

Taking into account all the above, the filter scheme can be represented as shown in Fig. 6. This model considers the parasitic capacitances of low-frequency coils and ceramic filter, the intrinsic resistance of low-frequency coils and equivalent series resistance of capacitors. Model settings: input and output impedance of 50 Ohms, modeling range of 10 kHz to 1 GHz. The frequency response of such a model is shown in Fig. 7 and differs significantly from the ideal filter model.

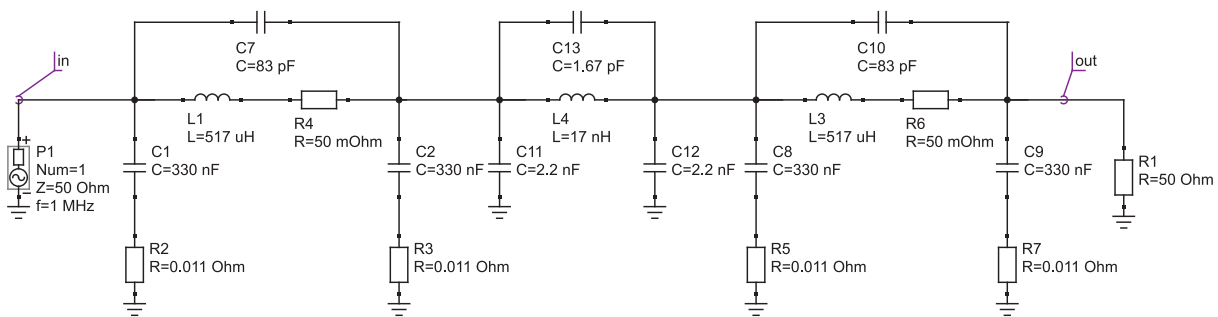

Fig. 6. Filter circuit with parasitic elements

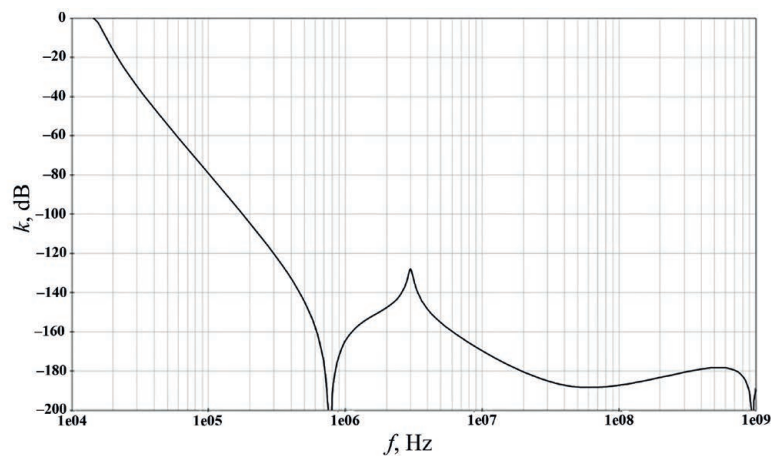

Fig. 7. Frequency response models with parasitic components

It was noted above that in the low-frequency range, the attenuation data can be considered plausible. Therefore, it should be noted that at the frequency of 50 kHz the attenuation coefficient is less than the required -60 dB. This section is shown on an enlarged scale in Fig. 8. It is possible to increase attenuation at a given frequency by increasing the capacitance of capacitors or the inductance of coils of low-frequency links.

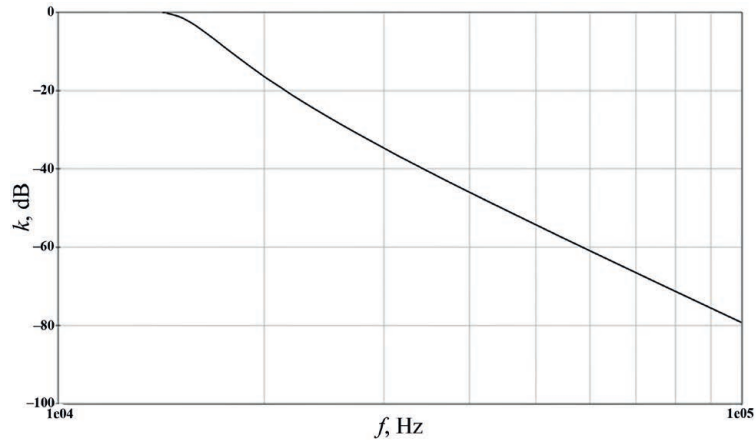

Fig. 8. Frequency response of the model in the range of 10–50 kHz

Since in the real design we are limited by the dimensions of the chassis, it is easier to increase the inductance of the coils by winding a certain number of turns on the magnetic circuit than to put larger capacitors. We will increase the inductance to 1 mH (Fig. 9).

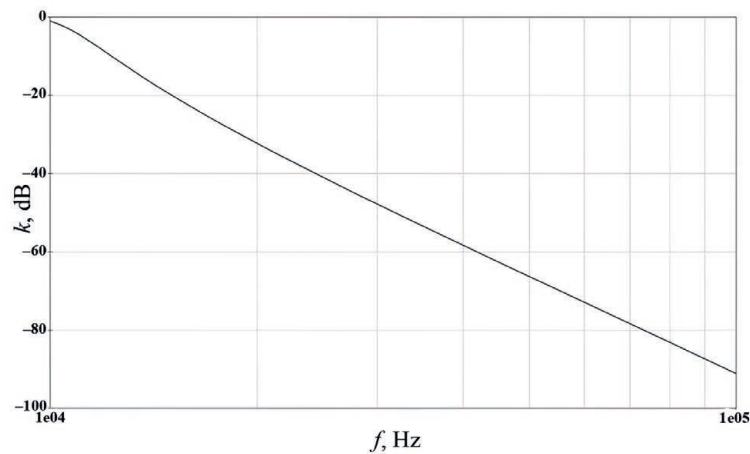

Fig. 9. Frequency response of the model with a modified inductance of coils in the range of 10–50 kHz

At the moment, the attenuation coefficient has become equal to -66 dB, which is within the acceptable range. To find the reasons for discrepancy between the attenuation coefficient required at high frequencies, let's simulate the frequency response of the filter in the short-circuit and idle mode (Fig. 10) in the range of 100 Hz to 1 GHz. The resistance is changed by scanning the parameter. We will set two values: 0.5 Ohms for short circuit and 50 kOhms for idle mode.

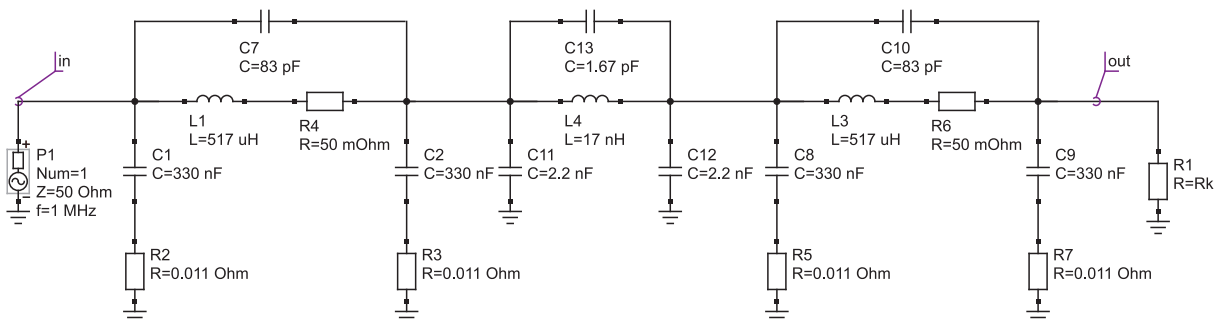

Fig. 10. A model for studying the operation of the filter in short-circuit and idle modes

It was suggested that the capacitance of ceramic filters B14 has a significant effect on the attenuation coefficient. Therefore, the manufacturer rejected all available B14 by capacity. As a result, filters with higher capacity values were installed in the products. Let's try to find out how much the capacity

of the ceramic filter within the tolerance affects the frequency response of the product. The simulation parameters are the same as in the study of short-circuit and idle modes. As a deployable parameter, the capacity of the ceramic filter is taken from 1.8 to 2.8 nF in increments of 200 pF (a total of 6 values). As a result, there were six frequency characteristics that completely coincide with each other. Hence, it was concluded that the change in the capacity of the B14 filter within the tolerance does not affect the frequency response of the product at all.

The influence of structural elements on the frequency response

In a high frequency range (100–300 MHz), the radiating properties of the structural elements rise dramatically. So, a metal screw located near the inductor turns into a pin antenna, starting to take some of the energy from the coil and radiate it into the surrounding space. Also, structural elements that can be considered short-circuited coils (fasteners, metal clamps, etc.) start interfering with the normal operation of the device (taking energy from inductive elements and re-emit it). Another danger of short-circuited coils is a decrease in the Q -factor of inductive elements located near, which worsens the resonant properties of the oscillatory circuits and, accordingly, their protective properties. Therefore, minimization in the design of elements that are potentially energy emitters is very important for the competent approach to high-frequency equipment design.

The filter under investigation consists of two compartments shielded by walls and a partition, in each of which there are two low-frequency U -shaped links: half of the upper channel according to the scheme (Fig. 1) and the lower one. The compartments are connected through a ceramic filter (B14). The inductors of each channel are mechanically connected through a common screw passing through both compartments. Low-frequency capacitors are fixed with metal brackets on the partition.

The inductor screw can additionally be considered as a common magnetic core for two inductors. It leads to the presence of a workaround for interference around the ceramic filter, which is why the attenuation coefficient drops. Also, metal brackets holding capacitors can be called parasitic, since they are short-circuited coils.

To assess the influence of structural elements on frequency characteristics, we need to modify the model. The modified model is shown in Fig. 11. To create a common magnetic field between two coils, a transformer $Tr1$ is connected in series with them with almost ideal characteristics: a small inductance of the windings and a transformation coefficient equal to one. Transformers $Tr2$ – $Tr5$ (with parameters similar to $Tr1$) are connected in series with low-frequency capacitors. Their primary winding simulates the inductance of the capacitor plates, the secondary winding is a short-circuited loop of the mounting bracket.

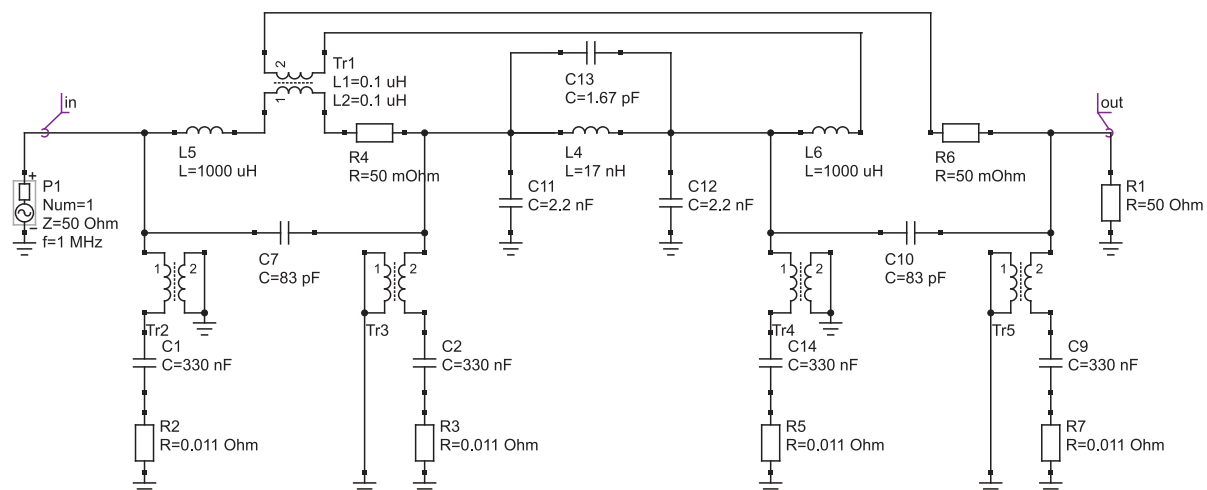

Fig. 11. A filter model that takes into account parasitic elements

Fig. 12 shows the frequency response of the new model. It's obvious, in the frequency from ~5 to 150 MHz, the attenuation drops and becomes much less than the required attenuation coefficient of -60 dB. In other frequency ranges, attenuation is also weakened significantly, although it remained within the acceptable limits.

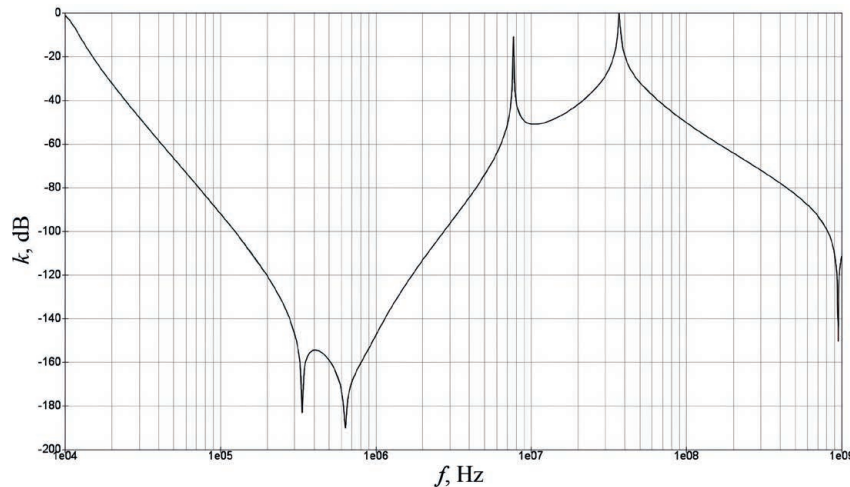

Fig. 12. Frequency response of a model that takes into account parasitic structural elements

Research results

The article considered an approach to the theoretical solution of practical problems of the development and modernization of noise-reduction filters. It was shown that in the low-frequency part of the range, the studied filter does not provide the necessary attenuation according to its parameters. For guaranteed compliance with the requirements, it is necessary to increase the inductance of the coils from 0.517 to 1.000 mH. The assumption made about the influence of the capacitance of the noise-reduction capacitor on the frequency response of the filter is refuted. The influence of the filter elements on its frequency response was found significant, so it's recommended to change the mechanical fasteners and holders of the elements.

It is impossible to consider all various factors affecting the work of the manufactured device, using one simulation software only within the framework of modeling. Therefore, in the future, the authors will continue the research aimed at modeling the volumetric filter model in electromagnetic compatibility modeling software, for example, HFSS.

Conclusion

Thus, it was found that the studied filter does not provide the necessary attenuation in the low-frequency and high-frequency range. To increase the attenuation coefficient in the lower part of the range, it is necessary to rise the inductance of low-frequency chokes. The parameters of the capacitors and ceramic filters don't affect the operation of the device. The characteristics of the filter are noticeably worsened by the attachment of low-quality capacitors and low-frequency chokes, which provide a parasitic capacitive connection between the compartments. To optimize the electrophysical characteristics, it is necessary to change the way the components are connected. This can be achieved by replacing the metal pin of the choke holder with a polyamide one. Mounting brackets for chokes must also be made out of a dielectric material.

References

1. Brinson M. E., Kuznetsov V. (2018) Extended Behavioural Device Modelling and Circuit Simulation with QUCS-S. *International Journal of Electronics*. 105 (3), 412–425.
2. Mita M., Maruyama S., Yi Y., Takahashi K., Fujita H., Toshiyoshi H. (2011) Multiphysics Analysis for Micro Electromechanical Systems Based on Electrical Circuit Simulator. *IEEJ Transactions on Electrical and Electronic Engineering*. 6 (2), 180–189.
3. Zonca A., Williams B., Rubin I., Meinhold P., Lubin P., Roucaries B., D'Arcangelo O., Franceschet C., Mennella A., Bersanelli M., Jahn S. (2010) Modeling the Frequency Response of Microwave Radiometers with QUCS. *Journal of Instrumentation*. 5 (12), T12001.
4. Amarel A. M. R., Cordoso A. J. M. (2008) An Economic Offline Technique for Estimating Equivalent Circuit of Aluminum Electrolytic Capacitors. *IEEE Transactions on Instrumentation and Measurement*. 57 (12), 2697–2710.

5. Kuhn W. B., Boutz A. P. (2010) Measuring and Reporting High Quality Factors of Inductors Using Vector Network Analyzers. *IEEE Transactions on Microwave Theory and Techniques*. 58 (4), 1046–1055.
6. Smith L. D., Hockanson D. (2001) Distributed SPICE Circuit Model for Ceramic Capacitors. *In. Proc. Electronic Components and Technology Conference*. 523–528.
7. Taylor J. R. (1996) An Introduction to Error Analysis: the Study of Uncertainties in Physical Measurements. *Sausalito, University Science Books*.
8. Rosa M. García Salvador, José A. Gázquez Parra, Nuria Novas Castellano (2013) Characterization and Modeling of High-Value Inductors in ELF Band Using a Vector Network Analyzer. *IEEE Transactions on Instrumentation and Measurement*. 62 (4), 415–423.
9. Satish Prabhakaran and Charles Sullivan (2002) Impedance-Analyzer Measurements of High-Frequency Power Passives: Techniques for High Power and Low Impedance. *In Proc. IEEE Industry Applications Conference, Pittsburgh, PA, USA*. 1360–1367.
10. Dosoudil R. (2012) Determination of Permeability from Impedance Measurement Using Vector Network Analyzer. *Journal of Electrical Engineering*. 63 (7), 97–101.

Author's contribution

All authors contributed equally to the writing of the article.

Information about the authors

Shmelkova A. A., Master's Student at the Department of Development and Technology of Electronic Devices of Kaluga Branch of Moscow State Technical University named after N. E. Bauman

Andreev V. V., Dr. of Sci., Professor, Professor at the Department of Development and Technology of Electronic Devices of Kaluga Branch of Moscow State Technical University named after N. E. Bauman

Drach V. E., Cand. of Sci., Associate Professor at the Department of Information Technology and Mathematics of Sochi State University

Address for correspondence

248000, Russian Federation,
Kaluga, Bazhenov St., 2
Kaluga Branch of Moscow State Technical University
named after N. E. Bauman
Tel.: +7 (4842) 74-40-32
E-mail: rpd-admin@inbox.ru
Shmelkova Anastasia Albertovna